

ATOM DC Series

SVTN B 01

Coreless DC motors
2 Pole Brushed DC Motors

ATOM DC Series

SVTN B 01

Coreless DC motors
2 Pole Brushed DC Motors



Cost effective



High power density



Long service life



The specific design construction of a coreless DC motor provides several advantages over traditional, iron core, technology. A first added value it is given from rotor lower mass and inertia, so very rapid acceleration and deceleration rates are possible. Furthermore the lack of iron reduce “iron losses” to provide higher efficiencies (up to 90 percent) than traditional DC motors. Last, but not least, coreless design reduces winding inductance, so sparking between the brushes and commutator is reduced, increasing motor life and reducing electromagnetic interference (EMI).

Servotecnica’s Coreless DC Motors are available on a wide range of sizes and high flexibility on mechanical custom requirements.

Benefits

High power density	Long operational lifetime
High efficiency	Cost-effective
High reliability	No cogging
Low inductance	
Low inertia	
Good heat dissipation	

Product code

SVTN B 01 - ○○◇◇ - □□ - ◇ - ○ △ ☆

B 01 Series

○ Diameter

◇ Length

□ Nominal Voltage

◇ Shaft
Single shaft [S]; Double shaft [D]

○ Connection
Terminals [O]

△ Commutator
Graphite brushes [G]; Metal brushes [M]

☆ Customizations

Features

Operating temperature	-30° +100° C
Connections	Terminals
Magnets	Neodymium
Construction technology	Coreless winding system
Estimated operating lifetime	Lifetime depends on motor working conditions. It can reach 10.000 work hours under optimal conditions (almost 100 hours under extreme conditions).

Feedback

Please contact factory for more details

Customizations

Flange	Shape
Shaft	Length/Diameter/D-Cut/double shaft
Winding	Special

Explanation of the performance diagram

The characteristic curve is composed of the following 4 key parameters:

No-load speed: It refers to the speed measured at the output shaft end when the motor is not connected to any load under the rated voltage, and the unit is RPM (revolutions per minute).

No-load current: It refers to the input current measured at the two terminals of the motor when the motor is not connected to any load at the rated voltage, and the unit is A (ampere).

Stall torque: The maximum torque measured by the motor at rated voltage due to the load causing the motor to stop rotating, in g.cm(g.cm).

Stalled current: This refers to the current measured in A (ampere) when the motor is stopped at the rated voltage due to the load.

It is recommended that you do not perform a stall operation on the motor, as this operation may cause the motor to “demagnetize” or even cause damage.

In general, the performance curve of the motor takes the output torque as the abscissa, and the speed, current, efficiency, and output power as the ordinate. correspondingly called: speed curve, current curve, efficiency curve, output power curve.

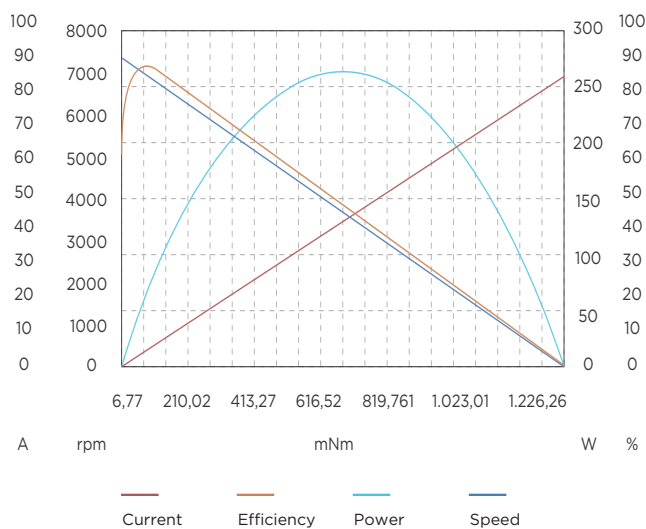

Speed curve

Is connected to the no-load speed NO point and stall torque Ts pointCurve, which indicates the speed of the motor under different load conditions. It is known that it decreases linearly with the increase in load.

Current curve

It is the curve shows the connection between two end points, no-load current and stall current. It describes motor current in different loading situation. As per diagram, current increase linearly with increasing torque.

Output power curve

It describes motor output power.

Efficiency curve

It describes motor efficiency and can be calculated with the following formula: $Eff(\%) = (\text{output power} / (\text{voltage} \times \text{current})) \times 100\%$. In general, the maximum efficiency point occurs in the area between stall torque/7 and stall torque/3. To design a suitable motor, maximum efficiency and maximum output power do not occur at the same point.

Table explanation SVTN B Series

Nominal voltage

It is the applied voltage between two powered phases in block commutation. All nominal data (lines 2 - 9) refer to this voltage. Lower and higher voltages are permissible, provided that limits are not exceeded.

No load speed

It is the speed at which the unloaded motor runs with the nominal voltage applied. It is proportional to the applied voltage.

No load current

This is the typical current that the unloaded motor draws when operating at nominal voltage. No load friction depends heavily on temperature. It decreases in extended operation and increases at lower temperatures.

Nominal speed

It is the speed set for operation at nominal voltage and nominal torque at a motor temperature of 25°C.

Nominal torque

It is the torque generated for operation at nominal voltage and nominal current at a motor temperature of 25°C. It is at the limit of the motor's continuous operation range. Higher torques heat up the winding too much.

Nominal current

It is the current in the active phase the nominal torque at the given nominal speed (= max. permissible continuous load current). The maximum winding temperature is reached at 25°C ambient temperature in continuous operation with Nominal current.

Stall torque

It is the linearly calculated load torque for motors that causes the shaft to stall at nominal voltage. This torque often cannot be achieved due to saturation effects.

Stall current

It is the quotient from nominal voltage and the motor's terminal resistance. Stall current is equivalent to stall torque. With larger motors, Stall current cannot be reached due to the amplifier's current limits.

Max. efficiency

It is the optimal relationship between input and output power at nominal voltage. Contact factory for more detail.

Terminal resistance

It is determined by the resistance at 25 °C between two motor phase.

Terminal inductance

It is the winding inductance between two motor phase.

Torque constant

Represents the quotient from generated torque and applicable current.

Speed constant

It indicates the theoretical no load speed per volt of applied voltage, disregarding friction losses.

Speed/torque gradient

The speed/torque gradient is an indicator of the motor's performance. It is based on the quotient of ideal no load speed and ideal stall torque (tolerance 3 20%).

Mechanical time constant

It is the time required for the rotor to accelerate from standstill to 63% of its no load speed.

Rotor moment of inertia

It is the mass moment of inertia of the rotor.

Thermal resistance housing-ambient

Characteristic values of thermal contact resistance without additional heat sinking. Lines 17 and 18 combined define the maximum heating at a given power loss (load). Thermal resistance Rth2 on motors with metal flanges can decrease by up to 80% if the motor is coupled directly to a good heat-conducting.

Thermal resistance winding-housing

Characteristic values of thermal contact resistance without additional heat sinking. Lines 17 and 18 combined define the maximum heating at a given power loss (load). Thermal resistance Rth2 on motors with metal flanges can decrease by up to 80% if the motor is coupled directly to a good heat-conducting.

Thermal time constant winding

These are the typical reaction times for a temperature change of winding and motor. It can be seen that the motor reacts much more sluggishly in thermal terms than the winding. The values are calculated from the product of thermal capacity and given heat resistances.

Thermal time constant motor

These are the typical reaction times for a temperature change of winding and motor. It can be seen that the motor reacts much more sluggishly in thermal terms than the winding. The values are calculated from the product of thermal capacity and given heat resistances.

Ambient temperature

Operating temperature range. This derives from the heat reliability of the materials.

Max. permissible winding temperature

Maximum permissible winding temperature.

Max. permissible speed

It is the maximum recommended speed based on thermal and mechanical perspectives. A reduced service life can be expected at higher speeds.

Radial play

Radial play is the bearing's radial movement

Max. axial load (dynamics)

Dynamic: axial loading permissible in operation. If different values apply for traction and thrust, the smaller value is given.

Max force for press fits (static)

Maximum axial force applying to the shaft at standstill if the force is not input at the other shaft end. This is not possible for motors with only one shaft end.

Max. radial load

The value is given for a typical distance from the front flange. As the distance increases, this value decreases.

Number of pole pairs

Number of north poles of the permanent magnet. The phase streams and commutation signals pass through per revolution p cycles. Servo-controllers require the correct details of the number of pole pairs.

Number of phases

All motors have three phases.

Weight



ATOM DC Series
SVTN B 01-1230 Metal brushes

2.5 Watt

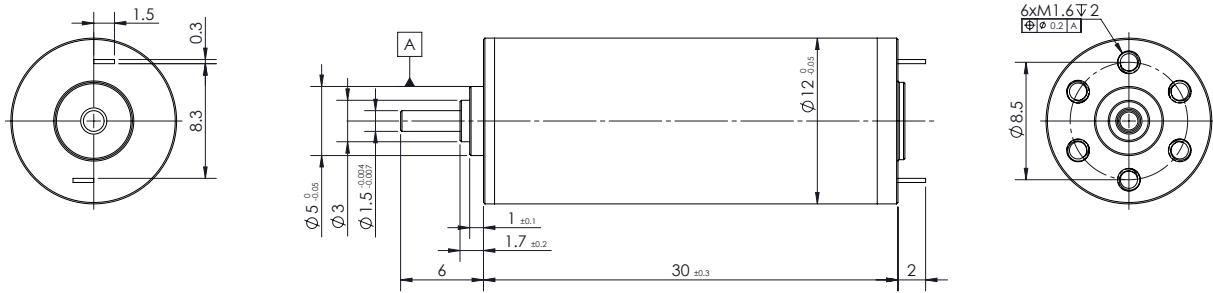

V 2.6.5

Values	Unit	SVTN B 01 1230-06..	1230-12..	1230-15..	1230-24..	
Motor Data						
1	Nominal voltage	V	6	12	15	24
2	No-load speed	rpm	13500	11400	13500	15000
3	No-load current	mA	22.0	16.0	15.0	8.0
4	Nominal speed	rpm	10800	9120	10800	12000
5	Nominal torque	mNm	1.4	1.5	1.8	2.7
6	Nominal current	A	0.4	0.2	0.2	0.2
7	Stall torque	mNm	7.0	7.6	9.2	13.4
8	Stall current	A	1.69	0.78	0.89	0.90
9	Max. efficiency	%	78.5	77.7	79.9	80.0
Characteristics						
10	Terminal resistance	Ω	3.55	15.38	16.85	26.67
11	Terminal inductance	mH	0.25	0.59	0.65	0.98
12	Torque constant	mNm/A	4.19	9.91	10.49	15.11
13	Speed constant	rpm/V	2250.0	950.0	900.0	625.0
14	Speed/torque gradient	rpm/mNm	1932.1	1495.9	1462.3	1115.5
15	Mechanical time constant	ms	5.7	4.3	4.5	3.2
16	Rotor inertia	gcm ²	0.28	0.27	0.29	0.27
Mechanical data						
17	Thermal resistance housing-ambient				33 K/W	
18	Thermal resistance winding-housing				7.0 K/W	
19	Thermal time constant winding				4.88 s	
20	Thermal time constant motor				229 s	
21	Ambient temperature				-20...+85°C	
22	Max. permissible winding temperature				+100°C	
23	Max. permissible speed				15000 rpm	
24	Max. axial load (dynamic)				0,1 N	
25	Max. force for press fits (static)				20 N	
26	Max. radial loading, 5mm from flange				5 N	
Other specifications						
27	Number of poles				2	
28	Weight				17 gr	

Gearbox combinations

SVTG B 10*

SVTG B 12*

*On request



ATOM DC Series
SVTN B 01-1320 Metal brushes

1.1 Watt

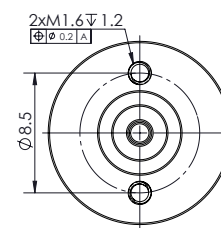
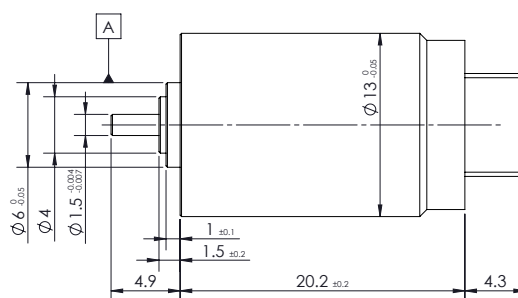
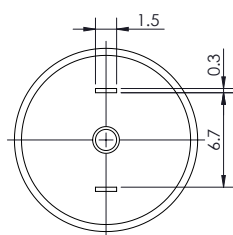
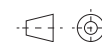

V 2.6.5

Values	Unit	SVTN B 01	1320-3.7..	1320-06..	1320-12..	1320-24..
Motor Data						
1	Nominal voltage	V	3.7	6	12	24
2	No-load speed	rpm	9500	12000	13000	12000
3	No-load current	mA	35.0	30	16	10
4	Nominal speed	rpm	7600	9600	10400	9600
5	Nominal torque	mNm	0.9	1.5	1.0	1.19
6	Nominal current	A	0.288	0.358	0.133	0.074
7	Stall torque	mNm	4.58	7.41	5.01	5.93
8	Stall current	A	1.30	1.63	0.60	0.33
9	Max. efficiency	%	69.9	71.1	70.0	68.21
Characteristics						
10	Terminal resistance	Ω	2.85	3.68	20	72.73
11	Terminal inductance	mH	0.09	0.12	0.50	1.30
12	Torque constant	mNm/A	3.62	4.66	8.58	18.52
13	Speed constant	rpm/V	2567.6	2000.0	1083.3	500.00
14	Speed/torque gradient	rpm/mNm	2075.1	1620.4	2594.5	2024.85
15	Mechanical time constant	ms	5.3	4.2	5.6	4.63
16	Rotor inertia	gcm ²	0.25	0.25	0.20	0.22
Mechanical data						
17	Thermal resistance housing-ambient				46 K/W	
18	Thermal resistance winding-housing				14 K/W	
19	Thermal time constant winding				5.18 s	
20	Thermal time constant motor				76.1 s	
21	Ambient temperature				-20...+85°C	
22	Max. permissible winding temperature				+100°C	
23	Max. permissible speed				19000 rpm	
24	Max. axial load (dynamic)				0.2 N	
25	Max. force for press fits (static)				20 N	
26	Max. radial loading, 5mm from flange				1.4 N	
Other specifications						
27	Number of poles				2	
28	Weight				13 gr	

Gearbox combinations

- SVTG B 10*
- SVTG B 12*

*On request

CORELESS
BRUSHED DC

servotecnica



ATOM DC Series SVTN B 01-1331 Metal brushes

3.5 Watt

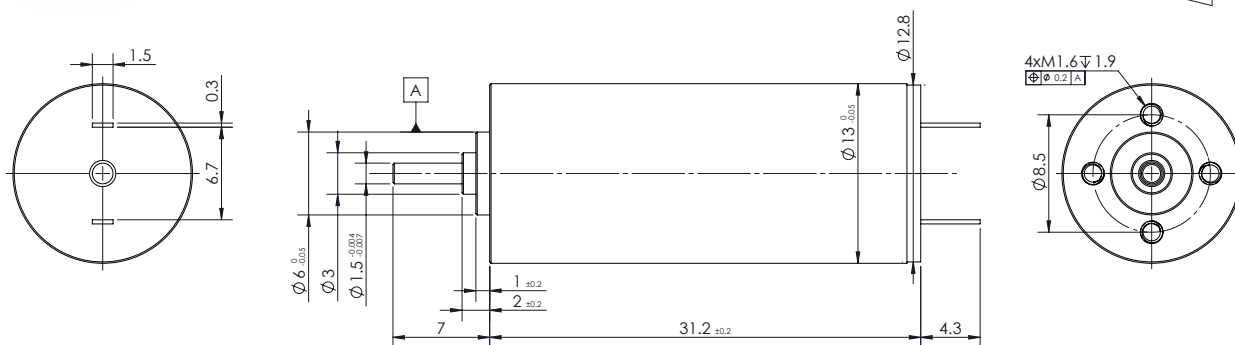

V 2.6.5

Values	Unit	SVTN B 01	1331-3..	1331-06..	1331-12..	1331-24..
Motor Data						
1	Nominal voltage	V	3	6	12	24
2	No-load speed	rpm	12000	11000	11600	16200
3	No-load current	mA	45.0	30.0	18.0	12.0
4	Nominal speed	rpm	9600	8800	9280	12960
5	Nominal torque	mNm	2.1	2.4	2.0	4.1
6	Nominal current	A	0.9	0.5	0.2	0.4
7	Stall torque	mNm	10.3	12.1	10.1	21.0
8	Stall current	A	4.400	2.400	1.080	1.570
9	Max. efficiency	%	80.8	75.8	69.4	70.5
Characteristics						
10	Terminal resistance	Ω	0.68	2.50	11.11	12.31
11	Terminal inductance	mH	0.05	0.12	0.27	0.75
12	Torque constant	mNm/A	2.36	5.12	9.60	13.78
13	Speed constant	rpm/V	4000.0	1833.3	966.7	675.0
14	Speed/torque gradient	rpm/mNm	1166.1	910.0	1150.3	618.5
15	Mechanical time constant	ms	8.0	6.2	7.9	4.2
16	Rotor inertia	gcm ²	0.65	0.65	0.65	0.65
Mechanical data						
17	Thermal resistance housing-ambient				33 K/W	
18	Thermal resistance winding-housing				7.0 K/W	
19	Thermal time constant winding				4.88 s	
20	Thermal time constant motor				259 s	
21	Ambient temperature				-20...+85°C	
22	Max. permissible winding temperature				+100°C	
23	Max. permissible speed				16200 rpm	
24	Max. axial load (dynamic)				0.2 N	
25	Max. force for press fits (static)				20 N	
26	Max. radial loading, 5mm from flange				1.4 N	
Other specifications						
27	Number of poles				2	
28	Weight				20 gr	

Gearbox combinations

SVTG B 10*

SVTG B 12*

*On request



ATOM DC Series
SVTN B 01-1524 Metal brushes

2.2 Watt

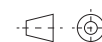

servotecnica

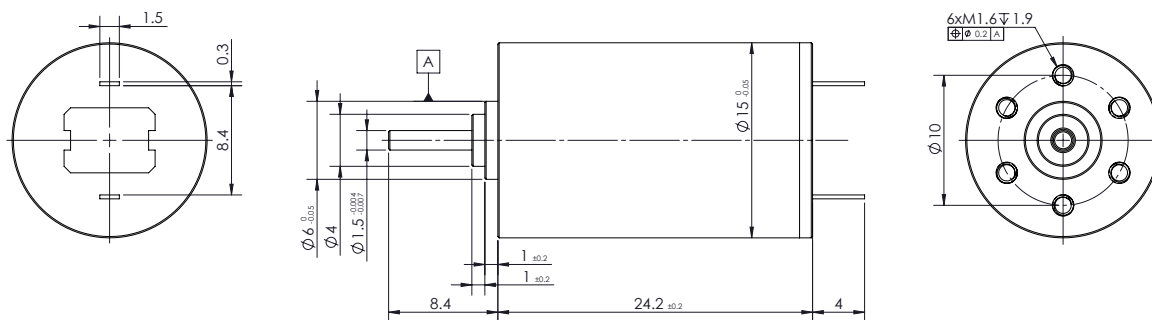

V 2.6.5

Values	Unit	SVTN B 01 1524-03..	1524-06..	1524-12..	1524-24..	
Motor Data						
1	Nominal voltage	V	3	6	12	24
2	No-load speed	rpm	10700	12300	11800	9500
3	No-load current	mA	40	20	11	4
4	Nominal speed	rpm	8560	9840	9440	7600
5	Nominal torque	mNm	1.6	1.8	1.7	1.4
6	Nominal current	A	0.6	0.4	0.2	0.1
7	Stall torque	mNm	7.8	9.1	8.7	7.0
8	Stall current	A	3.0	2.0	0.9	0.3
9	Max. efficiency	%	78.2	81.0	79.3	78.2
Characteristics						
10	Terminal resistance	Ω	1.00	3.00	13.04	80.00
11	Terminal inductance	mH	0.02	0.05	0.23	1.05
12	Torque constant	mNm/A	2.64	4.61	9.60	23.80
13	Speed constant	rpm/V	3566.7	2050.0	983.3	395.8
14	Speed/torque gradient	rpm/mNm	1368.4	1347.1	1352.9	1348.3
15	Mechanical time constant	ms	11.0	10.1	11.9	11.9
16	Rotor inertia	gcm ²	0.77	0.72	0.84	0.84
Mechanical data						
17	Thermal resistance housing-ambient				4.5 K/W	
18	Thermal resistance winding-housing				31 K/W	
19	Thermal time constant winding				2.4 s	
20	Thermal time constant motor				300 s	
21	Ambient temperature				-20...+85°C	
22	Max. permissible winding temperature				+100°C	
23	Max. permissible speed				12300 rpm	
24	Max. axial load (dynamic)				0.2 N	
25	Max. force for press fits (static)				20 N	
26	Max. radial loading, 5mm from flange				1.4 N	
Other specifications						
27	Number of poles				2	
28	Weight				22 gr	

Gearbox combinations

SVTG A 16

CORELESS
BRUSHED DC



ATOM DC Series
SVTN B 01-1625 Metal brushes

2.8 Watt

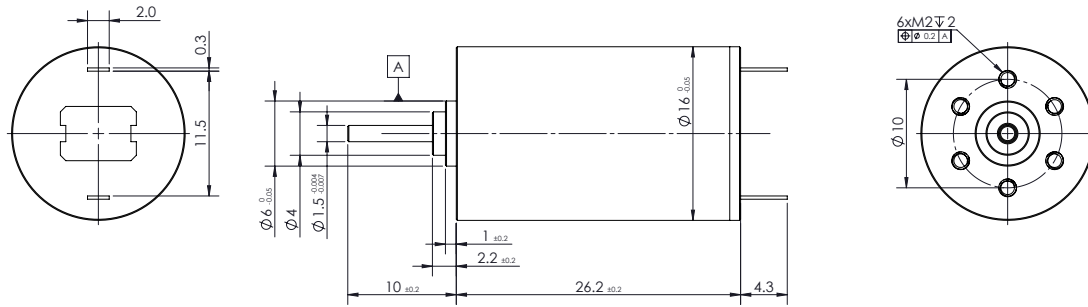
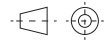

V 2.6.5

Values	Unit	SVTN B 01 1625-3.7..	1625-06..	1625-12..	1625-24..	
Motor Data						
1	Nominal voltage	V	3.7	6	12	24
2	No-load speed	rpm	8500	9800	10800	11000
3	No-load current	mA	50	20	15	6
4	Nominal speed	rpm	6800	7840	8640	8800
5	Nominal torque	mNm	2.5	2.8	2.7	3.0
6	Nominal current	A	0.67	0.50	0.27	0.15
7	Stall torque	mNm	12.7	14.0	13.5	15.2
8	Stall current	A	3.15	2.43	1.30	0.74
9	Max. efficiency	%	76.4	82.7	79.7	82.8
Characteristics						
10	Terminal resistance	Ω	1.17	2.47	9.23	32.43
11	Terminal inductance	mH	0.105	0.210	0.510	1.320
12	Torque constant	mNm/A	4.09	5.80	10.49	20.67
13	Speed constant	rpm/V	2297.3	1633.3	900.0	458.3
14	Speed/torque gradient	rpm/mNm	670.3	701.3	801.4	725.2
15	Mechanical time constant	ms	6.3	6.6	7.5	6.8
16	Rotor inertia	gcm ²	0.90	0.90	0.90	0.90
Mechanical data						
17	Thermal resistance housing-ambient			40.6 K/W		
18	Thermal resistance winding-housing			9.5 K/W		
19	Thermal time constant winding			5.33 s		
20	Thermal time constant motor			268 s		
21	Ambient temperature			-20...+85°C		
22	Max. permissible winding temperature			+100°C		
23	Max. permissible speed			11000 rpm		
24	Max. axial load (dynamic)			1.3 N		
25	Max. force for press fits (static)			15 N		
26	Max. radial loading, 5mm from flange			5 N		
Other specifications						
27	Number of poles			2		
28	Weight			24 gr		

Gearbox combinations

SVTG A 16



ATOM DC Series
SVTN B 01-1625 Graphite brushes

2.8 Watt

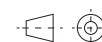

servotecnica

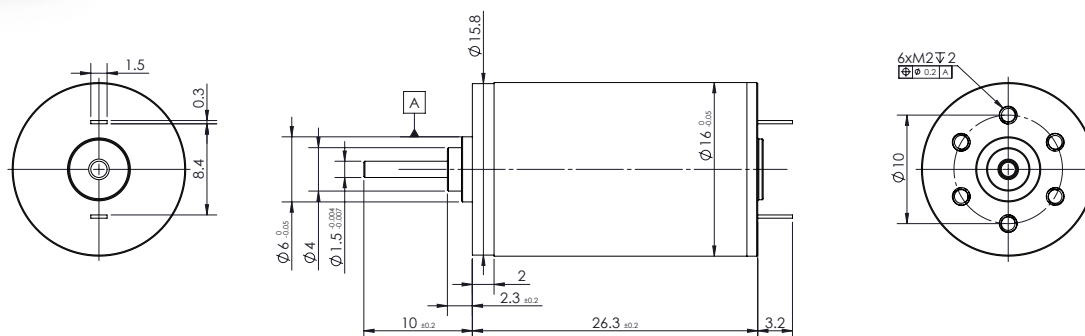

V 2.6.5

Values	Unit	SVTN B 01				
		1625-06-..	1625-09..	1625-12..	1625-24..	
Motor Data						
1	Nominal voltage	V	6	9	12	24
2	No-load speed	rpm	11500	12500	13600	11800
3	No-load current	mA	80	65	50	32
4	Nominal speed	rpm	8108	9125	9928	8614
5	Nominal torque	mNm	2.71	3.10	3.19	3.64
6	Nominal current	A	0.65	0.53	0.44	0.23
7	Stall torque	mNm	9.2	11.5	11.8	13.5
8	Stall current	A	2.00	1.80	1.50	0.82
9	Max. efficiency	%	64.0	65.6	66.8	66.2
Characteristics						
10	Terminal resistance	Ω	3.00	5.00	8.00	29.30
11	Terminal inductance	mH	0.10	0.18	0.34	1.10
12	Torque constant	mNm/A	4.78	6.63	8.14	18.75
13	Speed constant	rpm/V	1916.7	1388.9	1133.3	491.7
14	Speed/torque gradient	rpm/mNm	1252.3	1087.1	1151.5	708.8
15	Mechanical time constant	ms	12.6	10.7	10.8	7.6
16	Rotor inertia	gcm ²	0.96	0.94	0.90	1.03
Mechanical data						
17	Thermal resistance housing-ambient				40.6 K/W	
18	Thermal resistance winding-housing				9.5 K/W	
19	Thermal time constant winding				5.33 s	
20	Thermal time constant motor				268 s	
21	Ambient temperature				-20...+85°C	
22	Max. permissible winding temperature				+100°C	
23	Max. permissible speed				13600 rpm	
24	Max. axial load (dynamic)				1.3 N	
25	Max. force for press fits (static)				15 N	
26	Max. radial loading, 5mm from flange				5 N	
Other specifications						
27	Number of poles				2	
28	Weight				24 gr	

Gearbox combinations

SVTG A 16

CORELESS
BRUSHED DC



ATOM DC Series
SVTN B 01-1640 Metal brushes

4.2 Watt

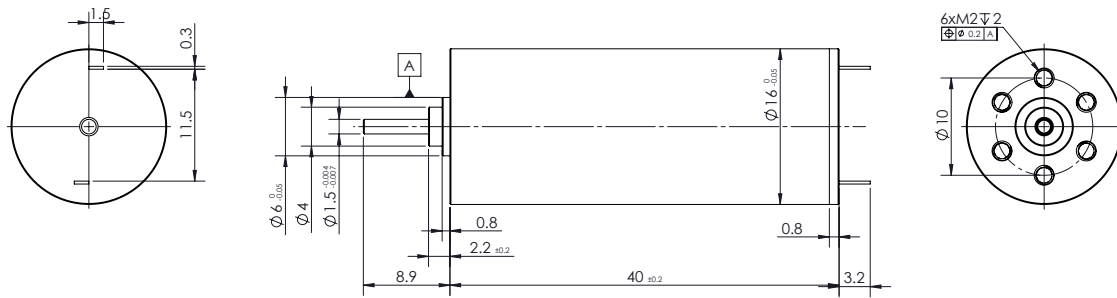

V 2.6.5

Values	Unit	SVTN B 01	1640-03..	1640-06..	1640-12..	1640-24..
Motor Data						
1	Nominal voltage	V	3	6	12	24
2	No-load speed	rpm	10000	9200	14000	13000
3	No-load current	mA	50	28	60	25
4	Nominal speed	rpm	8000	7360	11200	10400
5	Nominal torque	mNm	3.1	3.3	10.0	10.4
6	Nominal current	A	1.14	0.56	1.29	0.62
7	Stall torque	mNm	15.5	16.3	49.8	52.0
8	Stall current	A	5.5	2.7	6.2	3.0
9	Max. efficiency	%	81.8	80.6	81.3	82.6
Characteristics						
10	Terminal resistance	Ω	0.55	2.25	1.94	8.00
11	Terminal inductance	mH	0.01	0.06	0.15	0.56
12	Torque constant	mNm/A	2.84	6.16	8.11	17.48
13	Speed constant	rpm/V	3333.3	1533.3	1166.7	541.7
14	Speed/torque gradient	rpm/mNm	646.4	565.1	281.3	249.9
15	Mechanical time constant	ms	11.3	9.9	4.9	4.4
16	Rotor inertia	gcm ²	1.67	1.67	0.90	1.67
Mechanical data						
17	Thermal resistance housing-ambient				30 K/W	
18	Thermal resistance winding-housing				8.5 K/W	
19	Thermal time constant winding				10.6 s	
20	Thermal time constant motor				436 s	
21	Ambient temperature				-20...+85°C	
22	Max. permissible winding temperature				+100°C	
23	Max. permissible speed				14000 rpm	
24	Max. axial load (dynamic)				1.3 N	
25	Max. force for press fits (static)				15 N	
26	Max. radial loading, 5mm from flange				5 N	
Other specifications						
27	Number of poles				2	
28	Weight				40.5 gr	

Gearbox combinations

SVTG A 16



ATOM DC Series
SVTN B 01-1640 Graphite brushes

6.8 Watt

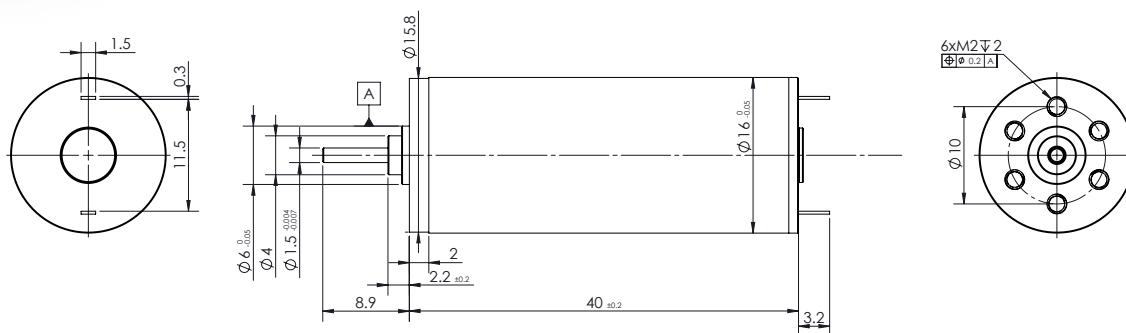
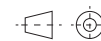

V 2.6.5

Values	Unit	SVTN B 01 1640-06..	1640-12..	1640-24..	
Motor Data					
1	Nominal voltage	V	6	12	24
2	No-load speed	rpm	12200	10400	10000
3	No-load current	mA	70	45	30
4	Nominal speed	rpm	9516	8112	7550
5	Nominal torque	mNm	4.5	6.6	8.7
6	Nominal current	A	1.04	0.65	0.41
7	Stall torque	mNm	20.5	29.9	35.3
8	Stall current	A	4.50	2.80	1.60
9	Max. efficiency	%	76.6	76.2	74.5
Characteristics					
10	Terminal resistance	Ω	1.33	4.29	15.00
11	Terminal inductance	mH	0.029	0.141	0.506
12	Torque constant	mNm/A	4.62	10.84	22.49
13	Speed constant	rpm/V	2033.3	866.7	416.7
14	Speed/torque gradient	rpm/mNm	595.7	348.2	283.2
15	Mechanical time constant	ms	10.4	6.1	5.0
16	Rotor inertia	gcm ²	1.67	1.67	1.69
Mechanical data					
17	Thermal resistance housing-ambient			30 K/W	
18	Thermal time constant winding			10.6 s	
19	Thermal time constant motor			436 s	
20	Ambient temperature			-20...+85°C	
21	Max. permissible winding temperature			+100°C	
22	Max. permissible speed			12200 rpm	
23	Max. axial load (dynamic)			1.3 N	
24	Max. force for press fits (static)			15 N	
25	Max. radial loading, 5mm from flange			5 N	
Other specifications					
26	Number of poles			2	
27	Weight			42 gr	

Gearbox combinations

SVTG A 16



ATOM DC Series
SVTN B 01-1725 Metal brushes

2.9 Watt

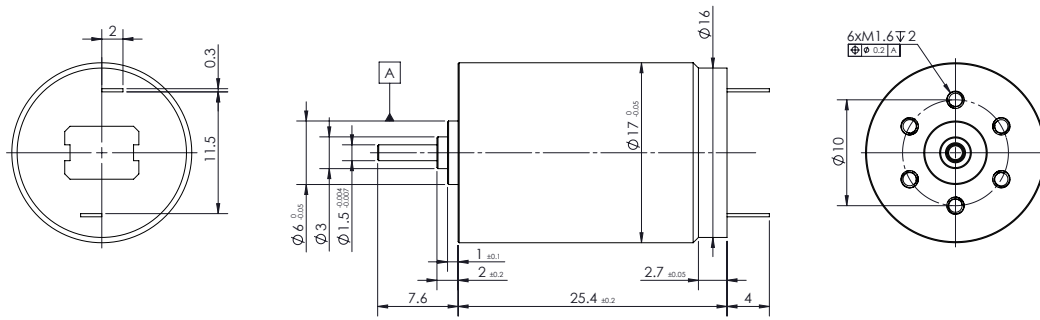

V 2.6.5

Values	Unit	SVTN B 01 1725-06..	1725-09..	1725-12..	1725-24..	
Motor Data						
1	Nominal voltage	V	6	9	12	24
2	No-load speed	rpm	10000	10000	10000	10000
3	No-load current	mA	23	30	20	8
4	Nominal speed	rpm	8000	8000	8000	8000
5	Nominal torque	mNm	2.19	2.06	2.68	2.72
6	Nominal current	A	0.41	0.28	0.24	0.14
7	Stall torque	mNm	11.0	10.3	13.4	13.6
8	Stall current	A	1.96	1.26	1.21	0.61
9	Max. efficiency	%	79.5	71.5	77.5	81.4
Characteristics						
10	Terminal resistance	Ω	3.06	7.14	5.71	22.86
11	Terminal inductance	mH	0.10	0.20	0.28	0.93
12	Torque constant	mNm/A	5.66	8.39	11.30	22.70
13	Speed constant	rpm/V	1666.7	1111.1	833.3	416.7
14	Speed/torque gradient	rpm/mNm	911.7	969.1	746.0	735.0
15	Mechanical time constant	ms	7.4	7.9	4.2	3.6
16	Rotor inertia	gcm ²	0.78	0.78	0.80	0.82
Mechanical data						
17	Thermal resistance housing-ambient			4 K/W		
18	Thermal resistance winding-housing			24.5 K/W		
19	Thermal time constant winding			2.6 s		
20	Thermal time constant motor			270 s		
21	Ambient temperature			-20...+85°C		
22	Max. permissible winding temperature			+100°C		
23	Max. permissible speed			10000 rpm		
24	Max. axial load (dynamic)			1.3 N		
25	Max. force for press fits (static)			15 N		
26	Max. radial loading, 5mm from flange			5 N		
Other specifications						
27	Number of poles			2		
28	Weight			28 gr		

Gearbox combinations

SVTG A 16



ATOM DC Series
SVTN B 01-1725 Graphite brushes

3.9 Watt

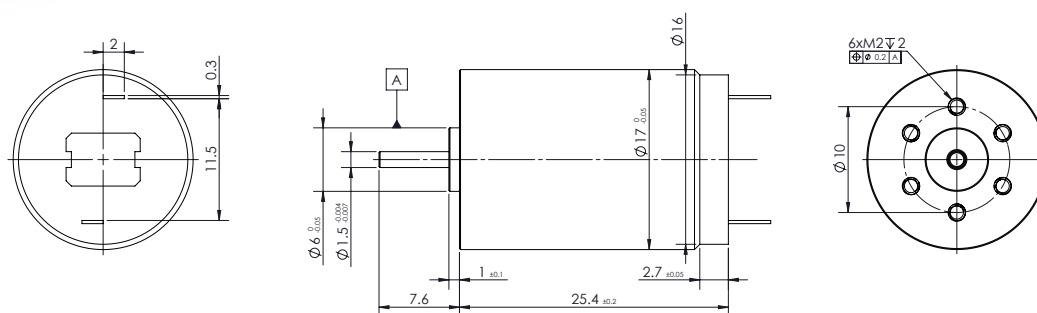
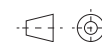

V 2.6.5

Values	Unit	SVTN B 01 1725-06..	1725-12..	1725-24..	
Motor Data					
1	Nominal voltage	V	6	12	24
2	No-load speed	rpm	11000	10000	10000
3	No-load current	mA	90	50	22
4	Nominal speed	rpm	8140	7400	7300
5	Nominal torque	mNm	3.55	3.28	3.81
6	Nominal current	A	0.79	0.35	0.19
7	Stall torque	mNm	13.66	12.60	14.10
8	Stall current	A	2.80	1.17	0.66
9	Max. efficiency	%	67.4	67.8	66.6
Characteristics					
10	Terminal resistance	Ω	2.14	10.20	36.40
11	Terminal inductance	mH	0.08	0.31	1.18
12	Torque constant	mNm/A	5.04	11.10	22.14
13	Speed constant	rpm/V	1833.3	833.3	416.7
14	Speed/torque gradient	rpm/mNm	805.2	793.6	584.2
15	Mechanical time constant	ms	7.6	5.5	5.5
16	Rotor inertia	gcm ²	0.90	0.90	0.90
Mechanical data					
17	Thermal resistance housing-ambient			4 K/W	
18	Thermal resistance winding-housing			24.5 K/W	
19	Thermal time constant winding			2.6 s	
20	Thermal time constant motor			270 s	
21	Ambient temperature			-20...+85°C	
22	Max. permissible winding temperature			+100°C	
23	Max. permissible speed			11000 rpm	
24	Max. axial load (dynamic)			1.3 N	
25	Max. force for press fits (static)			15 N	
26	Max. radial loading, 5mm from flange			5 N	
Other specifications					
27	Number of poles			2	
28	Weight			28 gr	

Gearbox combinations

SVTG A 16



ATOM DC Series
SVTN B 01-1740 Graphite brushes

14 Watt

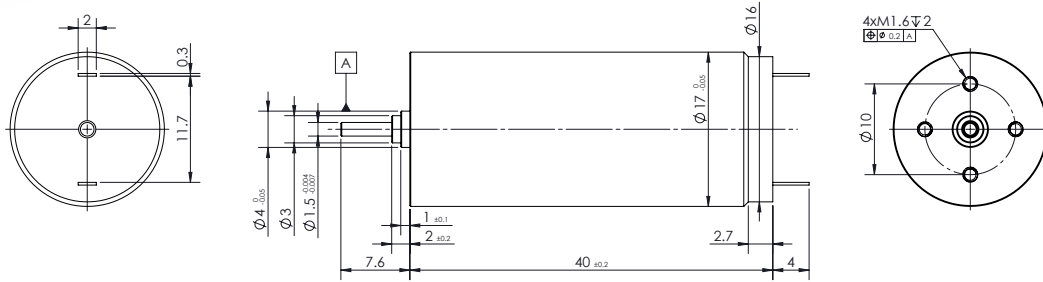

V 2.6.5

Values	Unit	SVTN B 01 1740-06..	1740-12..	1740-24..	
Motor Data					
1	Nominal voltage	V	6	12	24
2	No-load speed	rpm	13500	22000	16000
3	No-load current	mA	120	130	48
4	Nominal speed	rpm	11408	18590	13520
5	Nominal torque	mNm	6.0	9.5	9.8
6	Nominal current	A	1.54	1.97	0.74
7	Stall torque	mNm	38.5	61.2	63.1
8	Stall current	A	9.30	12.00	4.50
9	Max. efficiency	%	78.6	80.3	80.4
Characteristics					
10	Terminal resistance	Ω	0.65	1.00	5.33
11	Terminal inductance	mH	0.028	0.075	0.290
12	Torque constant	mNm/A	4.19	5.15	14.17
13	Speed constant	rpm/V	2250.0	1833.3	666.7
14	Speed/torque gradient	rpm/mNm	351.0	359.7	253.6
15	Mechanical time constant	ms	6.2	6.4	4.5
16	Rotor inertia	gcm ²	1.69	1.69	1.69
Mechanical data					
17	Thermal resistance housing-ambient			7 K/W	
18	Thermal resistance winding-housing			23 K/W	
19	Thermal time constant winding			8 s	
20	Thermal time constant motor			440 s	
21	Ambient temperature			-20...+85°C	
22	Max. permissible winding temperature			+100°C	
23	Max. permissible speed			22000 rpm	
24	Max. axial load (dynamic)			1.3 N	
25	Max. force for press fits (static)			15 N	
26	Max. radial loading, 5mm from flange			5 N	
Other specifications					
27	Number of poles			2	
28	Weight			48 gr	

Gearbox combinations

SVTG A 16



ATOM DC Series
SVTN B 01-2225 Metal brushes

4.2 Watt

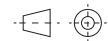

servotecnica

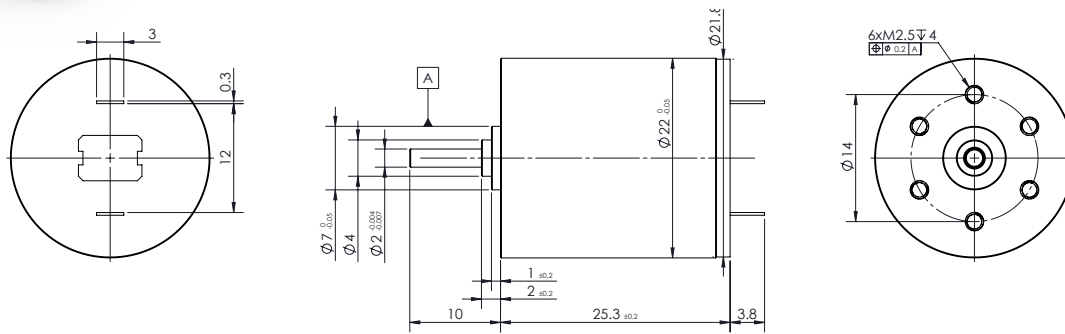

V 2.6.5

Values	Unit	SVTN B 01					
		2225-03..	2225-06..	2225-09..	2225-12..	2225-24..	
Motor Data							
1	Nominal voltage	V	3	6	9	12	24
2	No-load speed	rpm	7600	8200	8500	8300	7800
3	No-load current	mA	70	30	25	20	6
4	Nominal speed	rpm	6764	6806	7480	6889	6474
5	Nominal torque	mNm	2.35	3.28	2.60	4.13	3.44
6	Nominal current	A	0.70	0.50	0.29	0.32	0.12
7	Stall torque	mNm	21.3	19.3	21.7	24.3	20.2
8	Stall current	A	5.80	2.82	2.20	1.80	0.70
9	Max. efficiency	%	79.2	80.4	79.5	80.0	82.3
Characteristics							
10	Terminal resistance	Ω	0.52	2.13	4.09	6.67	34.29
11	Terminal inductance	mH	0.013	0.045	0.095	0.240	0.800
12	Torque constant	mNm/A	3.72	6.91	10.00	13.65	29.13
13	Speed constant	rpm/V	2533.3	1366.7	944.0	691.7	325.0
14	Speed/torque gradient	rpm/mNm	356.2	425.2	390.9	341.5	385.8
15	Mechanical time constant	ms	9.93	12.30	10.20	10.61	11.84
16	Rotor inertia	gcm ²	2.66	2.76	2.79	2.97	2.93
Mechanical data							
17	Thermal resistance housing-ambient				20 K/W		
18	Thermal resistance winding-housing				6.0 K/W		
19	Thermal time constant winding				10.2 s		
20	Thermal time constant motor				313 s		
21	Ambient temperature				-20...+85°C		
22	Max. permissible winding temperature				+100°C		
23	Max. permissible speed				8300 rpm		
24	Max. axial load (dynamic)				3.5 N		
25	Max. force for press fits (static)				44 N		
26	Max. radial loading, 5mm from flange				15 N		
Other specifications							
27	Number of poles				2		
28	Weight				48 gr		

CORELESS
BRUSHED DC

Gearbox combinations

- SVTG B 22
- SVTG B 24



ATOM DC Series
SVTN B 01-2225 Graphite brushes

8.1 Watt

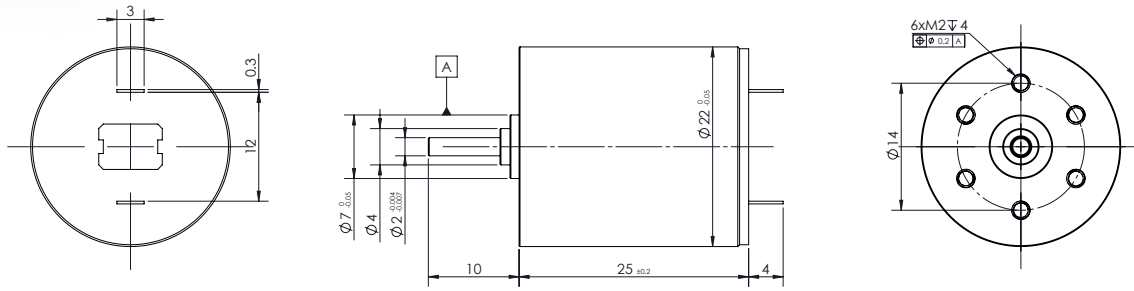
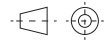

V 2.6.5

Values	Unit	SVTN B 01 2225-06..	2225-12..	2225-18..	2225-24..	
Motor Data						
1	Nominal voltage	V	6	12	18	24
2	No-load speed	rpm	13500	15800	11800	12000
3	No-load current	mA	100	90	60	45
4	Nominal speed	rpm	11340	13272	9676	9960
5	Nominal torque	mNm	3.67	5.13	6.24	5.56
6	Nominal current	A	0.98	0.81	0.50	0.34
7	Stall torque	mNm	22.9	32.1	34.7	32.7
8	Stall current	A	5.60	4.60	2.50	1.80
9	Max. efficiency	%	75.1	74.0	71.4	70.9
Characteristics						
10	Terminal resistance	Ω	1.07	2.61	7.20	13.33
11	Terminal inductance	mH	0.025	0.090	0.265	0.550
12	Torque constant	mNm/A	4.17	7.11	14.22	18.62
13	Speed constant	rpm/V	2250.0	1316.7	655.6	500.0
14	Speed/torque gradient	rpm/mNm	588.9	492.7	340.2	367.2
15	Mechanical time constant	ms	18.07	15.12	10.44	11.27
16	Rotor inertia	gcm ²	2.93	2.93	2.97	2.93
Mechanical data						
17	Thermal resistance housing-ambient				20 K/W	
18	Thermal resistance winding-housing				6.0 K/W	
19	Thermal time constant winding				10.2 s	
20	Thermal time constant motor				313 s	
21	Ambient temperature				-20...+85°C	
22	Max. permissible winding temperature				+100°C	
23	Max. permissible speed				15800 rpm	
24	Max. axial load (dynamic)				3.5 N	
25	Max. force for press fits (static)				44 N	
26	Max. radial loading, 5mm from flange				15 N	
Other specifications						
27	Number of poles				2	
28	Weight				48 gr	

Gearbox combinations

- SVTGB 22
- SVTGB 24



ATOM DC Series
SVTN B 01-2230 Metal brushes

5.5 Watt

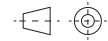

servotecnica

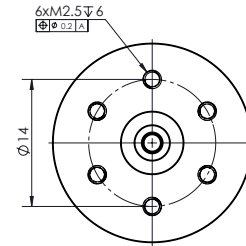
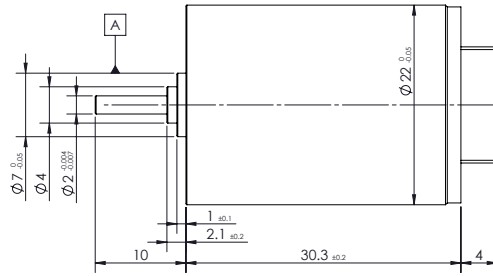
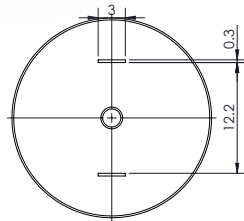

V 2.6.5

Values	Unit	SVTN B 01					
		2230-06..	2230-09..	2230-12..	2230-15..	2230-24..	
Motor Data							
1	Nominal voltage	V	6	9	12	15	24
2	No-load speed	rpm	8300	12200	10200	11000	9000
3	No-load current	mA	48	60	24	8	6
4	Nominal speed	rpm	7387	10858	9078	9790	8010
5	Nominal torque	mNm	2,81	2,39	2,73	2,7	1,37
6	Nominal current	A	0,46	0,41	0,27	0,22	0,06
7	Stall torque	mNm	25,6	21,7	24,9	24,5	12,4
8	Stall current	A	3,8	3,2	2,26	1,9	0,5
9	Max. efficiency	%	78,8	74,5	80,4	87,4	79,3
Characteristics							
10	Terminal resistance	Ω	1,58	2,81	5,31	7,89	48
11	Terminal inductance	mH	0,095	0,16	0,36	0,58	3,1
12	Torque constant	mNm/A	6,82	6,91	11,12	12,97	25,2
13	Speed constant	rpm/V	1383,3	1355,6	850	733,3	375
14	Speed/torque gradient	rpm/mNm	324,6	562,1	410,4	448,4	724,1
15	Mechanical time constant	ms	8,94	13,83	10,63	11,9	20,18
16	Rotor inertia	gcm ²	2,63	2,35	2,47	2,54	2,75
Mechanical data							
17	Thermal resistance housing-ambient				20 K/W		
18	Thermal resistance winding-housing				6.0 K/W		
19	Thermal time constant winding				10.2 s		
20	Thermal time constant motor				313 s		
21	Ambient temperature				-20...+85°C		
22	Max. permissible winding temperature				+100°C		
23	Max. permissible speed				12200 rpm		
24	Max. axial load (dynamic)				3,5 N		
25	Max. force for press fits (static)				44 N		
26	Max. radial loading, 5mm from flange				15 N		
Other specifications							
27	Number of poles				2		
28	Weight				54 gr		

CORELESS
BRUSHED DC

Gearbox combinations

- SVTG B 22
- SVTG B 24



ATOM DC Series
SVTN B 01-2230 Graphite brushes

7 Watt

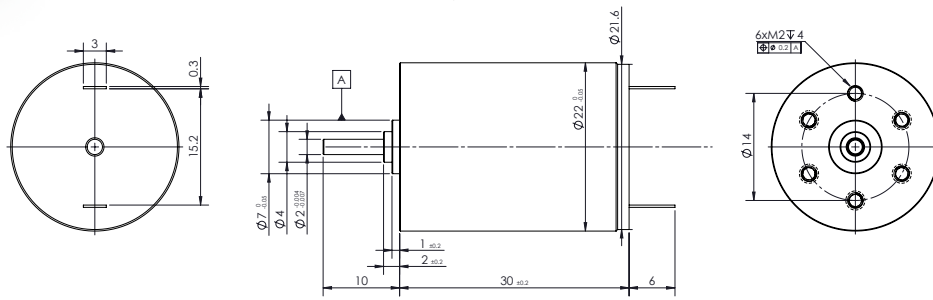

V 2.6.5

Values	Unit	SVTN B 01 2230-06..	2230-12..	2230-18..	2230-24..	
Motor Data						
1	Nominal voltage	V	6	12	18	24
2	No-load speed	rpm	11300	12200	10800	11000
3	No-load current	mA	90	65	45	30
4	Nominal speed	rpm	9492	10248	9234	9405
5	Nominal torque	mNm	3,91	5,22	5,79	5,26
6	Nominal current	A	0,88	0,63	0,42	0,29
7	Stall torque	mNm	24,45	32,6	39,96	36,26
8	Stall current	A	5	3,6	2,6	1,8
9	Max. efficiency	%	74,97	74,93	75,42	75,85
Characteristics						
10	Terminal resistance	Ω	1,2	3,33	6,92	13,33
11	Terminal inductance	mH	0,19	0,403	0,85	1,6
12	Torque constant	mNm/A	4,98	9,22	15,64	20,49
13	Speed constant	rpm/V	1883,3	1016,7	600	458,3
14	Speed/torque gradient	rpm/mNm	462,2	374,2	270,3	303,3
15	Mechanical time constant	ms	13,05	11,08	7,9	9,09
16	Rotor inertia	gcm ²	2,7	2,83	2,79	2,54
Mechanical data						
17	Thermal resistance housing-ambient				20 K/W	
18	Thermal resistance winding-housing				6.0 K/W	
19	Thermal time constant winding				10.2 s	
20	Thermal time constant motor				314 s	
21	Ambient temperature				-20...+85°C	
22	Max. permissible winding temperature				+100°C	
23	Max. permissible speed				12200 rpm	
24	Max. axial load (dynamic)				3,5 N	
25	Max. force for press fits (static)				44 N	
26	Max. radial loading, 5mm from flange				15 N	
Other specifications						
27	Number of poles				2	
28	Weight				54 gr	

Gearbox combinations

- SVTG B 22
- SVTG B 24

35 Watt



ATOM DC Series
SVTN B 01-2864 Graphite brushes

servotecnica

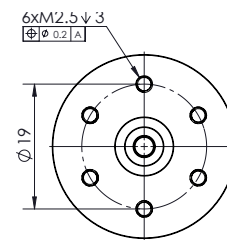
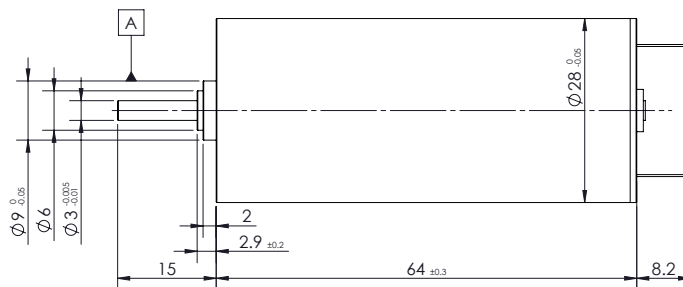
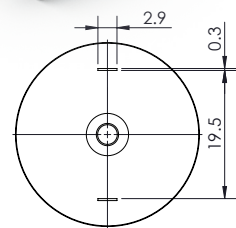

V 2.6.5

Values	Unit	SVTN B 01 2864-06..	2864-12..	2864-24..	
Motor Data					
1	Nominal voltage	V	6	12	24
2	No-load speed	rpm	7500	7300	7300
3	No-load current	mA	320	240	64
4	Nominal speed	rpm	6675	6497	6497
5	Nominal torque	mNm	19,63	26,46	32,71
6	Nominal current	A	2,92	1,95	1,11
7	Stall torque	mNm	178,5	240,5	297,4
8	Stall current	A	24	15,8	9,6
9	Max. efficiency	%	78,2	76,9	84,3
Characteristics					
10	Terminal resistance	Ω	0,25	0,76	2,5
11	Terminal inductance	mH	0,03	0,09	0,28
12	Torque constant	mNm/A	7,54	15,46	31,19
13	Speed constant	rpm/V	1250	608,3	304,2
14	Speed/torque gradient	rpm/mNm	42	30,3	24,5
15	Mechanical time constant	ms	7,02	6,56	4,97
16	Rotor inertia	gcm ²	15,94	20,63	19,32
Mechanical data					
17	Thermal resistance housing-ambient			8 K/W	
18	Thermal resistance winding-housing			3 K/W	
19	Thermal time constant winding			30 s	
20	Thermal time constant motor			600 s	
21	Ambient temperature			-20...+85°C	
22	Max. permissible winding temperature			+100°C	
23	Max. permissible speed			7500 rpm	
24	Max. axial load (dynamic)			7,5 N	
25	Max. force for press fits (static)			100 N	
26	Max. radial loading, 5mm from flange			25 N	
Other specifications					
27	Number of poles			2	
28	Weight			200 gr	

Gearbox combinations

- SVTG B 28
- SVTG B 32

CORELESS
BRUSHED DC



ATOM DC Series
SVTN B 01-3571 Graphite brushes

260 Watt

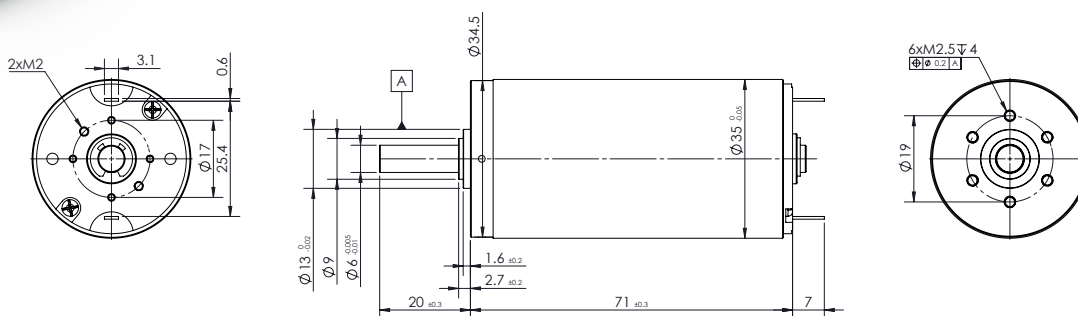

V 2.6.5

Values	Unit	SVTN B 01					
		3571-12..	3571-15..	3571-18..	3571-24..	3571-48..	
Motor Data							
1	Nominal voltage	V	12	15	18	24	48
2	No-load speed	rpm	7400	7100	6600	7900	7600
3	No-load current	mA	250	160	150	150	80
4	Nominal speed	rpm	6771	6497	6039	7229	6118
5	Nominal torque	mNm	115,17	81,76	82,35	117,62	245,1
6	Nominal current	A	7,71	4,23	3,32	4,22	4,16
7	Stall torque	mNm	1355	961,9	968,8	1383,8	1256,9
8	Stall current	A	88	48	37,5	48	21
9	Max. efficiency	%	89,6	88,8	87,8	89,1	88
Characteristics							
10	Terminal resistance	Ω	0,14	0,31	0,48	0,5	2,3
11	Terminal inductance	mH	0,05	0,12	0,17	0,19	0,7
12	Torque constant	mNm/A	15,44	20,11	25,94	28,92	60,1
13	Speed constant	rpm/V	616,7	473,3	366,7	329,2	158,3
14	Speed/torque gradient	rpm/mNm	5,5	7,4	6,8	5,7	6
15	Mechanical time constant	ms	4,57	5,87	5,43	4,48	4,61
16	Rotor inertia	gcm ²	79,98	76,01	76,06	74,80	72,85
Mechanical data							
17	Thermal resistance housing-ambient					6.2 K/W	
18	Thermal resistance winding-housing					2 K/W	
19	Thermal time constant winding					30.1 s	
20	Thermal time constant motor					707 s	
21	Ambient temperature					-20...+85°C	
22	Max. permissible winding temperature					+100°C	
23	Max. permissible speed					7900 rpm	
24	Max. axial load (dynamic)					7.5 N	
25	Max. force for press fits (static)					100 N	
26	Max. radial loading, 5mm from flange					25 N	
Other specifications							
27	Number of poles					2	
28	Weight					360 gr	

Gearbox combinations

- SVTG B 36
- SVTG B 42



ATOM DC Series
SVTN B 01-4050 Graphite brushes

87 Watt

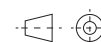

servotecnica

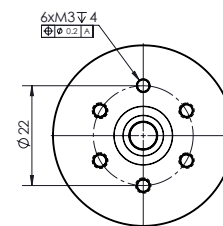
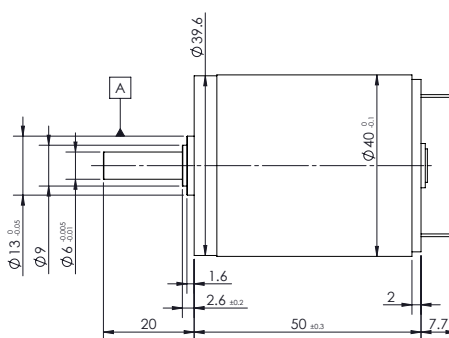
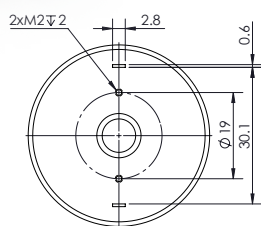

V 2.6.5

Values	Unit	SVTN B 01 4050-12..	4050-15..	4050-24..	4050-36..	4050-48..
Motor Data						
1	Nominal voltage	V	12	15	24	36
2	No-load speed	rpm	7600	7600	7850	8000
3	No-load current	mA	260	200	150	60
4	Nominal speed	rpm	6612	6612	6712	6640
5	Nominal torque	mNm	57,79	57,83	77,05	72,18
6	Nominal current	A	4,13	3,29	2,81	1,75
7	Stall torque	mNm	444,5	444,8	531,4	424,6
8	Stall current	A	30	24	18,5	10
9	Max. efficiency	%	82,2	82,6	82,8	85,1
Characteristics						
10	Terminal resistance	Ω	0,4	0,63	1,3	3,6
11	Terminal inductance	mH	0,043	0,087	0,18	0,32
12	Torque constant	mNm/A	14,95	18,69	28,96	42,71
13	Speed constant	rpm/V	633,3	506,7	327,1	222,2
14	Speed/torque gradient	rpm/mNm	17,1	17,1	14,8	18,8
15	Mechanical time constant	ms	6	6,56	5,75	6,92
16	Rotor inertia	gcm ²	33,54	36,66	37,14	35,08
Mechanical data						
17	Thermal resistance housing-ambient				4.9 K/W	
18	Thermal resistance winding-housing				2 K/W	
19	Thermal time constant winding				38 s	
20	Thermal time constant motor				780 s	
21	Ambient temperature				-20...+85°C	
22	Max. permissible winding temperature				+100°C	
23	Max. permissible speed				9500 rpm	
24	Max. axial load (dynamic)				9 N	
25	Max. force for press fits (static)				170 N	
26	Max. radial loading, 5mm from flange				80 N	
Other specifications						
27	Number of poles				2	
28	Weight				290 gr	

CORELESS
BRUSHED DC

Gearbox combinations

SVTG B 42



ATOM DC Series
SVTN B 01-4070 Graphite brushes

450 Watt

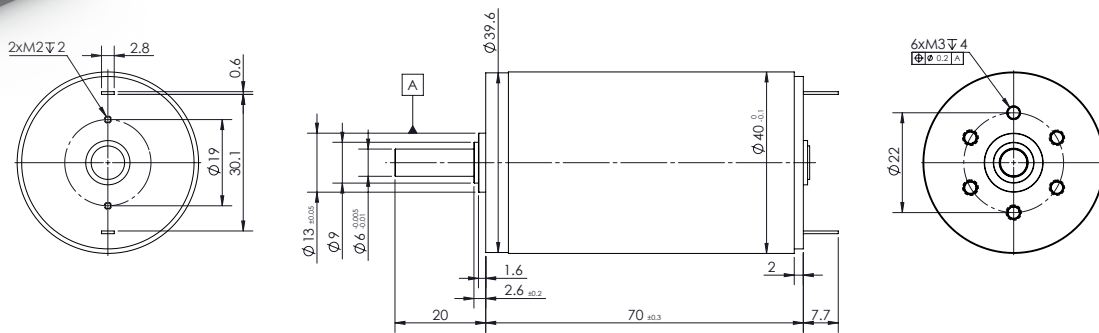

V 2.6.5

Values	Unit	SVTN B 01 4070-12..	4070-24..	4070-36..	4070-48..	4070-48..	
Motor Data							
1	Nominal voltage	V	12	24	36	48	48
2	No-load speed	rpm	8200	7600	7500	7600	2200
3	No-load current	mA	500	180	180	100	18
4	Nominal speed	rpm	7585	7030	6900	6992	1606
5	Nominal torque	mNm	161,41	181,25	189,36	196,86	172,37
6	Nominal current	A	12,09	6,2	4,33	3,37	0,85
7	Stall torque	mNm	2152,1	2416,7	2367	2460,7	638,4
8	Stall current	A	155	80,5	52	41	3,1
9	Max. efficiency	%	89	90,8	88,6	90,4	85,3
Characteristics							
10	Terminal resistance	Ω	0,08	0,3	0,69	1,17	15,5
11	Terminal inductance	mH	0,016	0,083	0,18	0,34	4,08
12	Torque constant	mNm/A	13,93	30,09	45,68	60,16	207,1
13	Speed constant	rpm/V	683,3	316,7	208,3	158,3	45,8
14	Speed/torque gradient	rpm/mNm	3,8	3,1	3,2	3,1	3,4
15	Mechanical time constant	ms	5,6	4,42	4,3	4,05	4,31
16	Rotor inertia	gcm ²	140,23	134,1	137,14	125,21	119,52
Mechanical data							
17	Thermal resistance housing-ambient				4.7 K/W		
18	Thermal resistance winding-housing				1.9 K/W		
19	Thermal time constant winding				41.5 s		
20	Thermal time constant motor				809 s		
21	Ambient temperature				-20...+85°C		
22	Max. permissible winding temperature				+100°C		
23	Max. permissible speed				7600 rpm		
24	Max. axial load (dynamic)				9 N		
25	Max. force for press fits (static)				170 N		
26	Max. radial loading, 5mm from flange				80 N		
Other specifications							
27	Number of poles				2		
28	Weight				485 gr		

Gearbox combinations

SVTG B 42